

How To Work An Ovolo

The ovolo is a classical moulding consisting of a quarter circle, radius $a-b$, bounded by two fillets c and d . The line formed by $a-d$ being perpendicular to that formed by $a-c$.

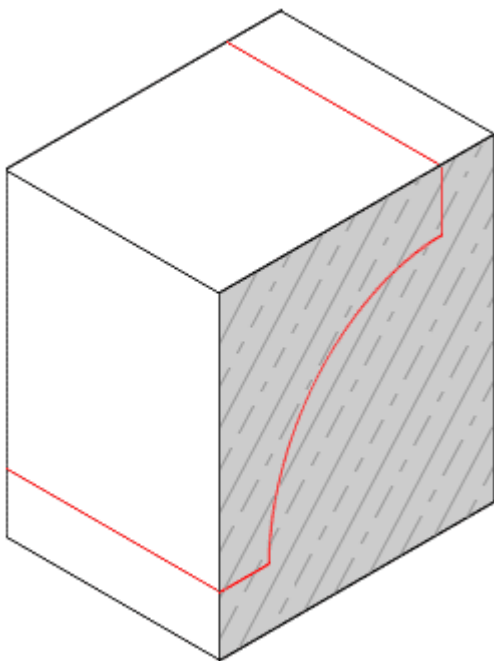
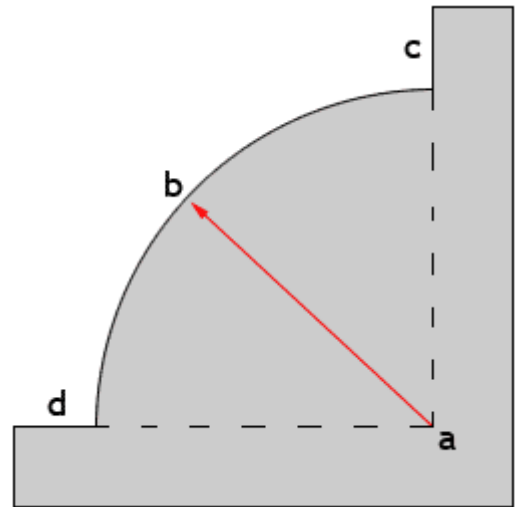

The process of working an ovolo begins by marking the template onto the parallel joints of the stone using a scribe. Templates for stone are traditionally made from zinc sheeting.

The next step is to scribe a large chamfer. Note from the picture that the chamfer is marked on such that it touches two of the outer edges of the mould to be worked. Working to two points of the mould like this maximises efficiency.

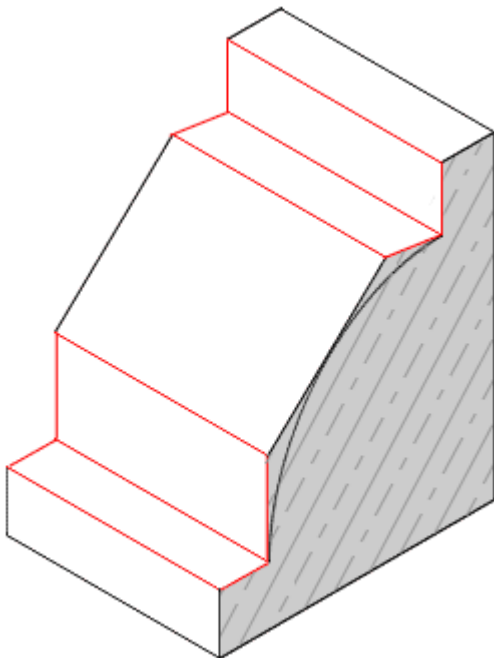
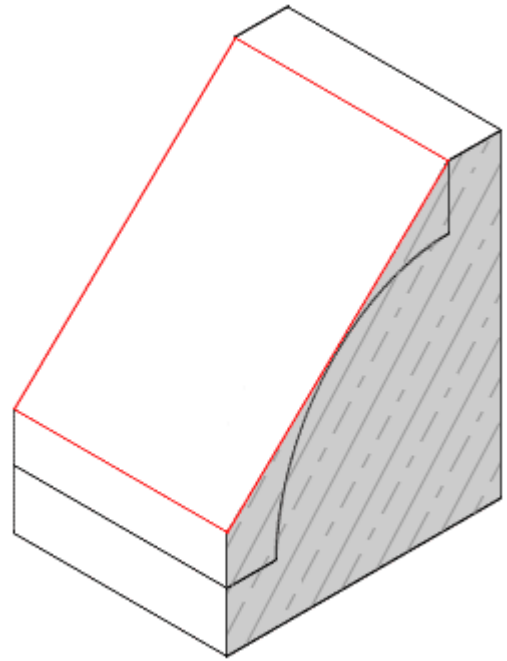

With the large chamfer finished, the two fillets are worked. As with all stages of working stone, the fillets are checked with a straight edge for trueness.

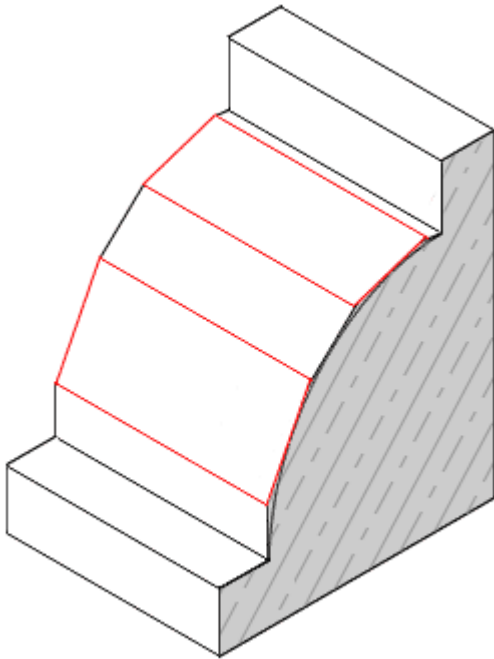

With the large chamfer finished, the two fillets are worked. As with all stages of working stone, the fillets are checked with a straight edge for trueness.

Following on from the previous stage the curve of the mould is refined by working further chamfers with each smaller than the last until a true curve is produced. The final stage is to tool the curve over to remove any flat spots with a bolster and dummy.

